

# PRODUCT DATA SHEET

Metacaulk® BlazeSeal™  
Fire Door Strip



## 1. Product Description

Aflexible, highly intumescent firestop material used in fire rated door and door frame assemblies. BlazeSeal™ is designed to maintain positive pressure as required in testing to the new fire door standards of the Uniform Building Code, UBC 7-2 and UL10C. Our advanced technology allows the material to display multiple staged intumescence. This type of expansion offers superior fire protection while reducing the amount of material required to achieve the desired fire rating. In addition, BlazeSeal™ forms a strong char to seal the door to frame clearance, thus preventing the passage of flames, smoke, and hot gases. BlazeSeal™ stands up to the hose stream test required by UBC 7-2.

## Metacaulk® BlazeSeal™ Features

- Easy to install
- Cost effective / Less material required

- Versatile, Flexible
- Highly intumescent (multiple staged)
- Wide size range for less waste
- Forms a strong char to more easily pass the hose stream test and increased pressure requirements

## 2. Material Properties

Contains no carcinogenic fillers  
Contains no solvents  
Standard Color: Dark Gray  
(Colored protective PVC coating available)

Activation of Intumescence:

Expansion Begins 375°F (190°C)

## 3. Testing Data

**Metacaulk® BlazeSeal™ has been tested to the requirements of UBC 7-2,** it was tested in accordance with the German Institute of Building Technology standard DIN 4102-1, and meets the requirements of the British Standard B.S. 476. It has been tested as a through penetration

firestop sealant to ASTM E-814 / UL 1479. Complies to Required Environmental Exposure Testing of Accelerated Aging and High Humidity as per UL 1479 Fire Test of Through-Penetration Firestops.

Degree of intumescence per DIN standard

- ≥18x with weight imposed
- ≥37x free intumescing

## ASTM E 84, UL 723 Tunnel Test

Flame Spread	5
Smoke Index	5

## 4. Application and Installation

Metacaulk® BlazeSeal™ is installed as an integral part of fire door assemblies to provide a positive pressure seal in the clearance area between the door and frame or at the assembly threshold in the event of fire. BlazeSeal™ may also be used to prevent the passage of flames, hot gases, or smoke through hardware, such as closers and locks and may be used as a

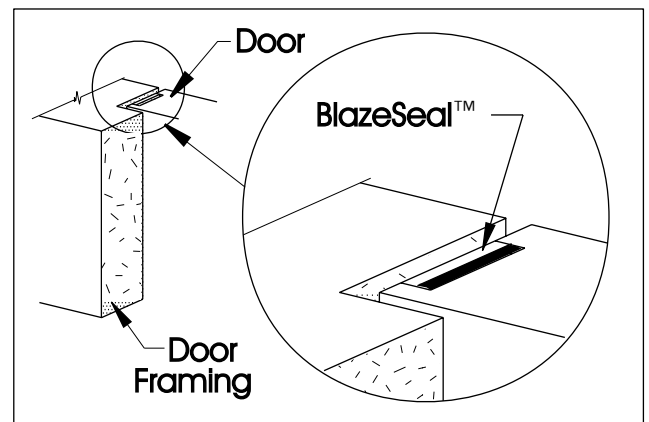
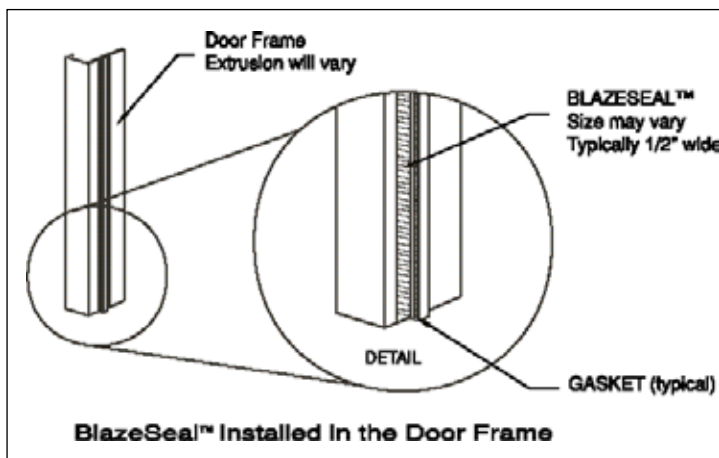

glazing seal in frame assemblies utilizing fire rated glass in both doors and side lites.

BlazeSeal™ is installed on either the door frame or the leaf of the door. It may be installed with an appropriate adhesive either in a channel or flush to the surface. BlazeSeal™ may be supplied with a factory applied pressure sensitive adhesive film. Consult UL Directory for complete instructions and system listings.

## 5. Storage & Handling

Metacalk® BlazeSeal™ should be stored between 35°F (2°C) and 120°F (49° C). Keep products stored under protective cover, in their original containers. A stock rotation program is recommended. Shelf life of the product is indefinite.

## 6. Availability

Metacalk®BlazeSeal™ is available in a broad range of standard widths, lengths and thickness as well as custom sizes. BlazeSeal™ is ready to use, requires no further preparation.

## 7. Limitations

To be used only in the tested configurations or as recommended by RectorSeal.

## 8. Cautions

**FOR CHEMICAL EMERGENCY, SPILL, LEAK, FIRE, EXPOSURE OR ACCIDENT, CALL CHEMTREC-DAY OR NIGHT 1-800-424-9300.**

**PRECAUTIONS:** Do not take internally. May be harmful if swallowed. May cause eye and skin irritation if prolonged or repeated contact occurs. Wash after handling. **FIRST AID:** For any overexposure, get immediate medical attention after first aid is given. **Eyes-** Flush 15 minutes with clean water. **Skin-**Wash with soap and water. **Ingestion-**Only if conscious, give large amounts of water and INDUCE VOMITING. **FIRE AND SPILLS:** Use water fog, CO<sub>2</sub>, foam, or dry chemicals. Wipe up spills to prevent footing hazard. Clean up with scrapers and water. **STORAGE AND HANDLING:** Store away from heat sources. **KEEP OUT OF REACH OF CHILDREN.**

For additional information, refer to Material Safety Data Sheet.

**For additional technical service,  
call: 713-263-8001 or 1-800-231-3345  
fax: 713-263-7577 or 1-800-441-0051**

RECTORSEAL  
2601 SPENWICK DRIVE HOUSTON, TEXAS 77055  
WWW.RECTORSEAL.COM

## 9. LIMITED WARRANTY

RectorSeal makes the Limited Express Warranty that when the instructions for storage and handling of our products are followed we warrant our products to be free from defects. THIS LIMITED EXPRESS WARRANTY IS EXPRESSLY IN LIEU OF ANY OTHER EXPRESS OR IMPLIED WARRANTIES, INCLUDING ANY IMPLIED WARRANTY OF MERCHANTABILITY OR FITNESS FOR A PARTICULAR PURPOSE, AND OF ANY OTHER OBLIGATION ON THE PART OF RECTORSEAL. The sole remedy for breach of the Limited Express Warranty shall be the refund of the purchase price. All other liability is negated and disclaimed, and RectorSeal shall not be liable for incidental or consequential damages.

Suggestions and recommendations covering the use of our products are based on our past experience and laboratory findings. However, as we have no control as to the methods and conditions of application, we only assume responsibility for the uniformity of our products within manufacturing tolerances.